



SHENZHEN KMTEKLED PHOTOELECTRICITY CO. , LTD

Product Specification



KMT CV-COB SERIES

Content

1. Product Description	3
2. 150mmx168.75mm Module Specification	3
3. 600mmx337.5mm Cabinet Specification	3
4. Module Dimension Structure	4
5. Module Picture	4
6. Cabinet Dimension Structure	5
7. Cabinet Picture	5
8. Technical Parameter	6
9. Connecting Diagram	7
10. Packing and After-sale Service	8

1. Product Description

This product adopts COB encapsulation technology, which is different from the traditional SMD surface-mount encapsulation. It integrates the light-emitting RGB chip on the PCB board instead of soldering LED lamp to the PCB one by one. This technology effectively improves the reliability, light color and protection performance of LED display.

1.1 Application Scope

This technical specification is only applicable to KMT indoor CV-COB series product.

Module size:150x168.75mm and its supporting die cast aluminum cabinet:600*337.5mm.

1.2 Product Features

- 600mm x 337.5mm die-casting aluminum cabinet with very thin thickness 32.5mm. compatible pitch 0.93/1.25/1.56/1.875
- Flip chip COB support common cathode solution, low consumption, and more stable.
- The Horizontal and vertical viewing angle reach 170 degrees, wider than SMD screen.
- Big high-quality chip, pure gold bonding wires, and pads are immersed gold technology, which is more reliable.
- High refresh rate at low gray, refresh rate $\geq 3840\text{HZ}$, Grey scale $\geq 14\text{Bit}$.
- Excellent heat dissipation and low light decay, PCB board dissipate heat directly, extended service life.
- Module face IP65,water-proof, dust-proof, anti-oxidation, anti-static, anti-impact.
- 16:9 ratio cabinet design,2K/4K/8K dot to dot match resolution,100% front service.

2. 150mmx168.75mm Module Specification

Item	Specification	Module Picture
Series	CV-Flip chip COB Series	
Material	No Plastic housing	
Pixel Pitch	0.9375mm, 1.25mm, 1.5625mm, 1.875mm	
Resolution	160×180, 120×135, 96×108, 80×90	
Module Size	150mm x168.75mm (W x H)	
Module Weight	150g±10g	

3. 600mmx337.5mm Cabinet Specification

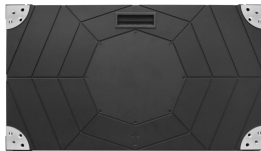
Item	Specification	Cabinet Picture
Series	CV-Flip chip COB Series	
Cabinet Material	Die-casting aluminum	
Pixel Pitch	0.9375mm, 1.25mm, 1.5625mm, 1.875mm	
Resolution	640×360, 480×270, 384×216, 320×180	
Cabinet Size	600mm x 337.5mm*32.5mm (W x H x D)	
Cabinet Weight	4.3Kg	

4. Module Dimension Structure

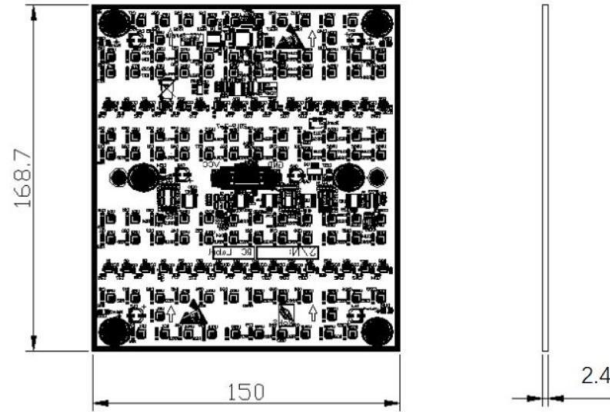

5. Module Picture

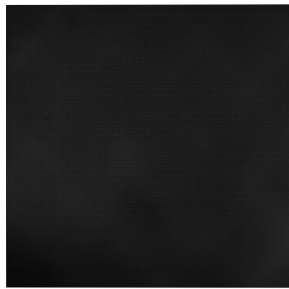

Front View

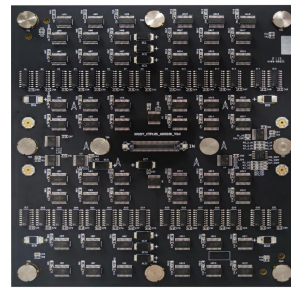

Back View

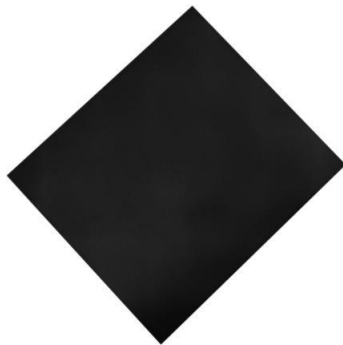

Side View

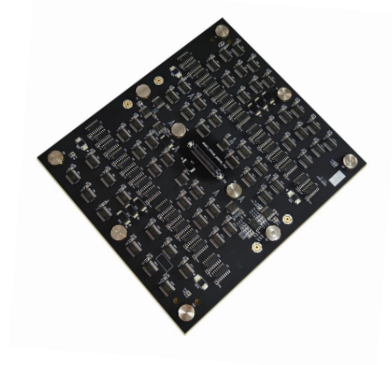

Side View

6. Cabinet Dimension Structure

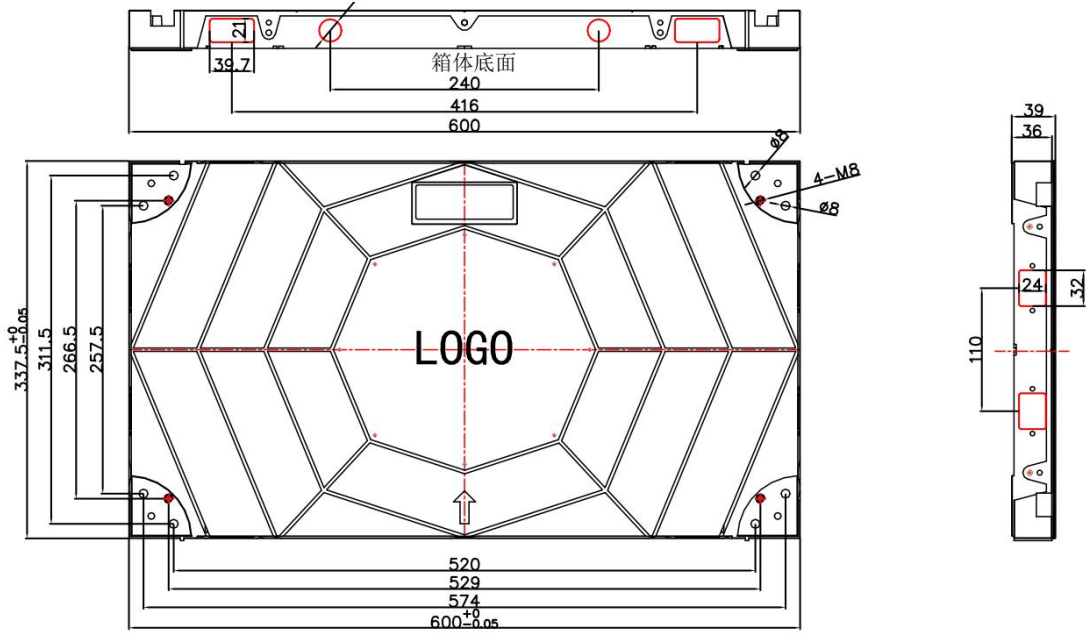

7. Cabinet Picture

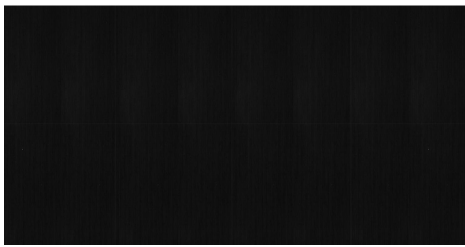

Front View

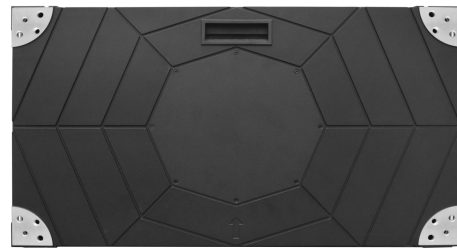

Back View

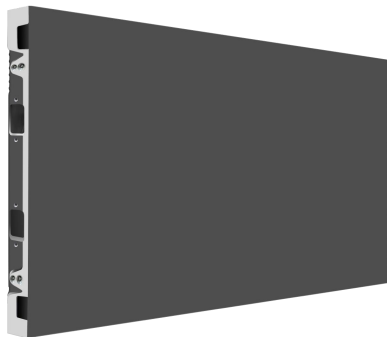

Side View



Side View

8. Technical Parameter

Item		CV0.93	CV1.25	CV1.56	CV1.87
Technical	Pixel Pitch (mm)	0.9375	1.25	1.5625	1.875
	LED Configuration	FLIP CHIP COB 1R1G1B Common cathode			
	LED Type	2 x 4	2 x 4	2 x 4	2 x 4
	Physical Density (dot/m ²)	1,137,778	640,000	409,600	284,444
	Module Size (W ×H ×D) mm	150x168.75	150x168.75	150x168.75	150x168.75
	Module Resolution (W ×H)	160x180	120x135	96*108	80*90
	Module Material	No Plastic housing			
	Cabinet Size (W ×H ×D) mm	600x337.5x32.5	600x337.5x32.5	600x337.5x32.5	600x337.5x32.5
	Cabinet resolution (W×H) dot	640x360	480x270	384x216	320x180
	Cabinet Material	Die Casting Aluminum			
	Scanning Mode	1/60	1/45	1/48	1/30
	Cabinet Flatness (mm)	≤0.10			
	Grey Scale (Bit)	14Bit+Control Software 2Bit=16Bit			
	Protection Level	LED Lamp side IP65, rear IP45			
	Installation/Service Method	Front or back installation/Front service			
Optical	Brightness	50-500cd/m ² adjustable			
	Color Temperature	3200-9300K adjustable			
	Brightness Uniformity	≥98%			
	Color Uniformity	Within 0.003Cx, Cy			
	Horizontal/Vertical View Angle	≥170°			
	Contrast Ratio	≥10000:1			
	Color Calibration of Single Dot	Yes			
	Brightness Calibration of Single Dot	Yes			
Operation	Drive Mode	Constant Current Drive			
	Standard Receiving Card	A10S PLUS-N/K10	A8S-N/K8	A8S-N/K8	A8S-N/K8
	Refresh Frame Frequency	50/60 Hz			
	Max Refresh Rate	≥2880Hz	≥3840Hz		
	Network Connection Port	RJ45			
	Input Voltage AC	110-220V			
	Module Max Current DC	DC4.2V	DC4.2V	DC4.2V	DC4.2V
	Module Input Voltage DC	2.5A	2.5A	2.5A	2.5A
	Cabinet Max Power Consumption	≤450W/m ²	≤450W/m ²	≤450W/m ²	≤450W/m ²
	Cabinet Aver. Power Consumption	≤150W/m ²	≤150W/m ²	≤150W/m ²	≤150W/m ²
	Working Temperature	-20℃~+50℃			
	Working Humidity	10%~95%RH			

8.1 Package Comparison.

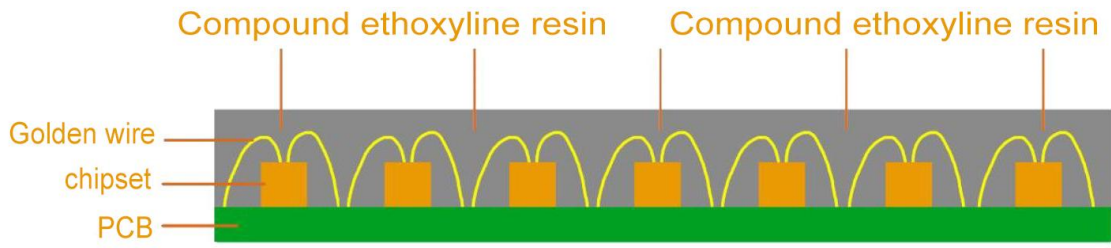

COB (regular technology)

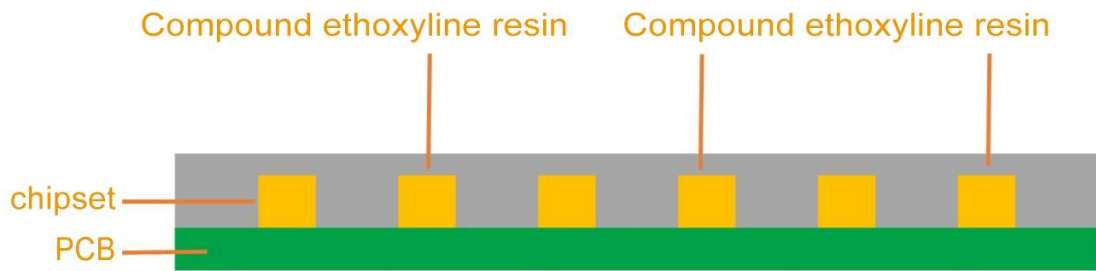

Flip Chip COB

8.2 Optical Feature

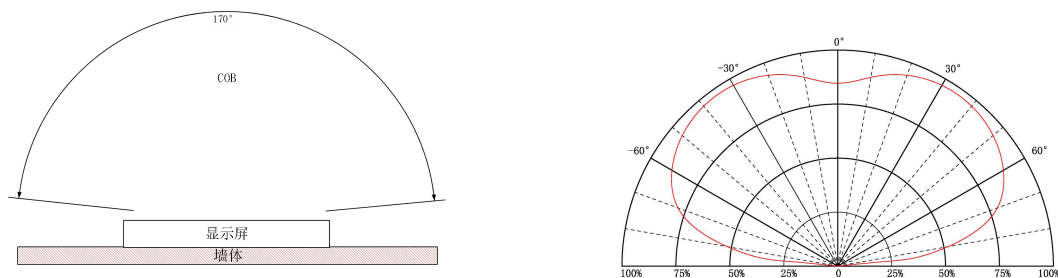

Light Angle and Schematic Diagram

9. Connecting Diagram

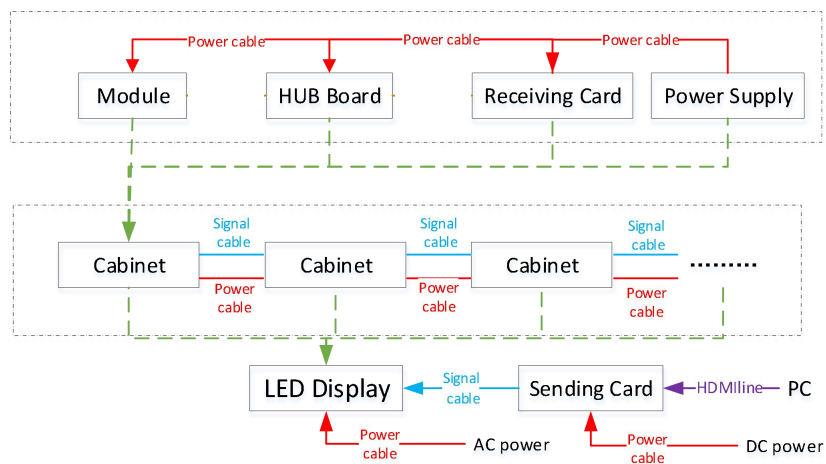

10. Packing and After-sale Service

10.1 Packing

Plywood case/Honeycomb carton/Flight case option



10.2 After-sale Service

If need any help during using KMT display, please for free to contact your salesman.